

N5120

BS 84

DIN EN 22568



CHARACTERISTICS

HSS

LH





Technical drawing

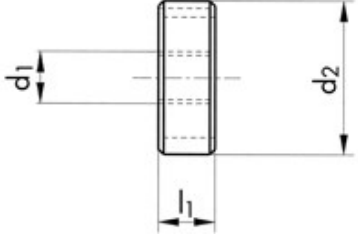

Profile sketch



Tool data

ID	D1	ϕd_1	Tol	P	l1	d2		
104328	W3/4	19.05	MCLH	2.540	18.0	45.00	5	18.89

Product range N5120 W3/4 LH

ID	D1	ϕd_1	Tol	P	l1	d2		
104320	W1/8	3.18	MC	0.635	5.0	20.00	4	3.09
104333	W5/32	3.97	MC	0.794	7.0	20.00	4	3.88
104325	W3/16	4.76	MC	1.058	7.0	20.00	4	4.66
104318	W1/4	6.35	MC	1.270	7.0	20.00	4	6.24
130215	W6.82x0.625	6.82		0.625	9.0	25.00	4	6.75
104331	W5/16	7.94	MC	1.411	9.0	25.00	4	7.82
104329	W3/8	9.53	MC	1.588	11.0	30.00	4	9.40
104336	W7/16	11.11	MC	1.814	11.0	30.00	4	10.98
104316	W1/2	12.70	MC	2.117	14.0	38.00	4	12.56
104334	W5/8	15.88	MC	2.309	18.0	45.00	4	15.72
104327	W3/4	19.05	MC	2.540	18.0	45.00	5	18.89
104328	W3/4	19.05	MCLH	2.540	18.0	45.00	5	18.89
104322	W1	25.40	MC	3.175	22.0	55.00	5	25.27
104315	W1 3/8	34.93	MC	4.233	25.0	65.00	6	34.77